



Community Development Department
11 English Street
Petaluma, CA 94952
<http://cityofpetaluma.net>

Building Division
Phone: (707) 778-4301
Fax: (707) 778-4498
To schedule inspections: (707) 778-4479
Email: cdd@ci.petaluma.ca.us

Commercial Handrail Information

The following information is based on the 2010 California Building Code and 2009 International Building Code. For complete handrail information please refer to the 2010 CBC, Sections 1012 and 1133 B.4.1. Note that all stairs regardless of the number of risers must be built to comply with the current codes

HANDRAIL SIZE AND PROJECTION

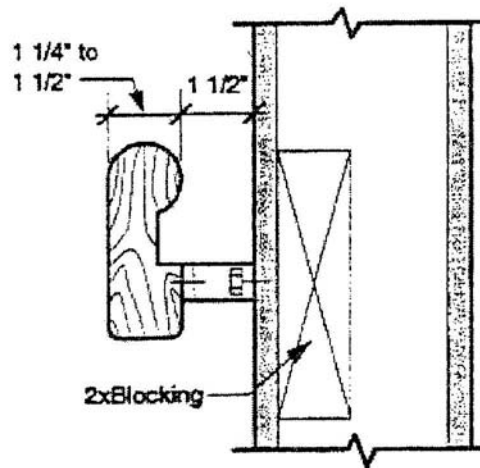

General. Stairways shall have handrails on each side, and every stairway required to be more than 88 inches in width shall be provided with not less than one intermediate handrail for each 88 inches of required width. Intermediate handrails shall be spaced approximately equally across the entire width of the stairway.

Exceptions:

- Stairways serving one individual dwelling unit in Group R, Division 1 or 3. Occupancies may have one handrail, except that stairways open on one or both sides shall have handrails on the open side or sides.
- Stairways having three risers or less and stairways giving access to portable work stands less than 30 inches high are not required to have handrails.

Note:

Handrail projection, configuration and recession shall be the same as required for ramp handrails.

Handrail Configuration. Handrails shall be 34 to 38 inches above nosing of treads.

Handrail Extension. Handrails shall extend a minimum of 12 inches beyond the top nosing and 12 inches plus the tread width beyond the bottom nosing.

Newel Posts. The ends of handrails shall terminate in newel posts or safety terminals.

Hazards. Where the extension of the handrail in the direction of the stair would create a hazard, the termination shall be made either rounded or returned smoothly to the floor, wall or post. Where the stairs are continuous from landing to landing, the inner rail shall be continuous and need not extend out into the landing.

Handgrips. Handrails projecting from the wall shall have a space of not less than 1-1/2 inches between the wall and the handrail. **The grip portion shall not be less than 1-1/4 inches nor more than 2 inches, or a shape that provides an equivalent gripping surface.** All surfaces shall be smooth with no sharp corners. Handrails shall not rotate within their fittings.

Handrails For Ramps. Section 1133B.5.5.1 Handrails are required on ramps that provide access if the slope exceeds one unit vertical in 20 units horizontal (5% slope), except that at exterior door landings, handrails are not required on ramps less than 6 inches (152mm) rise or 72 inches (1829mm) in length. Handrails shall be placed on each side of each ramp, shall be continuous the full length of the ramp, shall be 34 to 38 inches (864 to 965mm) above the ramp surface to the top of the handrails, shall extend a minimum of 1 foot (305mm) beyond the top and bottom of the ramp and shall be parallel with the floor or ground surface. The inside handrail on switchback or dogleg ramps shall always be continuous. Handrails may project into the required clear width a distance of 3 ½ inches (89mm) maximum from each side of a ramp at the handrail height. The ends of handrails shall be either rounded or returned smoothly to floor, wall or post. Handrails projecting from a wall shall have a space of 1 ½ inches (38mm) between the wall and the handrail. Handrails may be located in a recess if the recess is a maximum of 3 inches (76mm) deep and extends at least 18 inches (457mm) above the top of the rail. The grip portion shall not be less than 1 ½ inches (32mm) nor more than 1 ½ inches (38mm) in a cross-sectional nominal dimension or the shape shall provide an equivalent gripping surface, and all surfaces shall be smooth with no sharp corners. Handrails shall not rotate within their fittings. Any wall or other surface adjacent to the handrail shall be free of sharp or abrasive elements. Edges shall have a minimum radius of 1/8 inch (3mm).

Exceptions:

- Handrails at ramps immediately adjacent to fixed seating in assembly areas are not required.
- Ramps that require handrails and that serve one individual dwelling unit in Group R, Division 1 or 3. Occupancies may have one handrail except that such ramps open on one or both sides shall have handrails provided on the open side or sides.
- Curb ramps do not require handrails.